

ITR 90

FullRange® Bayard-Alpert Gauge

Operating Instructions



Product Identification

In all communications with Pfeiffer Vacuum, please specify the information on the product nameplate. For convenient reference copy that information into the space provided below.

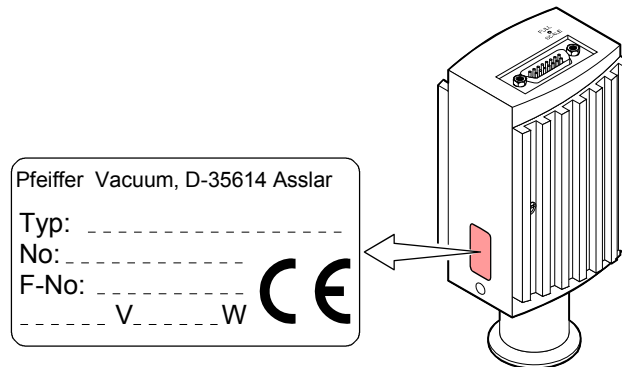

Validity

This document applies to products with the following part numbers:

PT T12 146 300 (vacuum connection DN 25 ISO-KF)
 PT T12 366 300 (vacuum connection DN 40 CF-R)

The part number (No.) can be taken from the product nameplate.



If not indicated otherwise in the legends, the illustrations in this document correspond to the gauge with no. PT T12 146 300. They apply to other gauges by analogy.

All ITR 90 versions are shipped with an instruction sheet (→ [1]).

We reserve the right to make technical changes without prior notice.

All dimensions in mm.

Intended Use

The ITR 90 gauges have been designed for vacuum measurement of gases and gas mixtures in a pressure range of 5×10^{-10} ... 1000 mbar.

They must not be used for measuring flammable or combustible gases in mixtures containing oxidants (e.g. atmospheric oxygen) within the explosion range.

The gauges can be operated in connection with a Pfeiffer Vacuum controller or with other control devices.

Functional Principle



Over the whole measuring range, the gauge has a continuous characteristic curve and its measuring signal is output as logarithm of the pressure.

The gauge functions with a Bayard-Alpert hot cathode ionization measurement system ($p < 2.0 \times 10^{-2}$ mbar) and a Pirani measurement system ($p > 5.5 \times 10^{-3}$ mbar). In the overlapping pressure range of 2.0×10^{-2} ... 5.5×10^{-3} mbar, a mixed signal of the two measurement systems is output. The hot cathode is switched on by the Pirani measurement system only below the switching threshold of 2.4×10^{-2} mbar (to prevent filament burn-out). It is switched off when the pressure exceeds 3.2×10^{-2} mbar.



Contents

Product Identification	2
Validity	2
Intended Use	2
Functional Principle	2
1 Safety	4
1.1 Symbols Used	4
1.2 Personnel Qualifications	4
1.3 General Safety Instructions	4
1.4 Liability and Warranty	4
2 Technische Data	5
3 Installation	8
3.1 Vacuum Connection	8
3.1.1 Making the Flange Connection	9
3.1.2 Removing and Installing the Electronics Unit	9
3.1.3 Using the Optional Baffle	10
3.2 Electrical Connection	12
3.2.1 Use With Pfeiffer Vacuum Gauge Controllers	12
3.2.2 Use With Other Controllers	12
4 Operation	15
4.1 Measuring Principle, Measuring Behavior	15
4.2 Operational Principle of the Gauge	16
4.3 Putting the Gauge Into Operation	16
4.4 Degas	17
4.6 RS232C Interface	17
4.6.1 Description of the Functions	17
4.6.1.1 Output String (Transmit)	17
4.6.1.2 Input String (Receive)	19
5 Deinstallation	20
6 Maintenance, Repair	21
6.1 Maintenance	21
6.1.1 Cleaning the Gauge	21
6.2 Adjusting the Gauge	21
6.2.1 Adjustment at Atmospheric Pressure	21
6.2.2 Zero Point Adjustment	22
6.3 What to Do in Case of Problems	23
6.4 Replacing the Sensor	24
7 Options	25
8 Spare Parts	25
9 Storage	25
10 Returning the Product	26
11 Disposal	26
Appendix	27
A: Relationship Output Signal – Pressure	27
B: Gas Type Dependence	28
C: Literature	29

For cross-references within this document, the symbol (→  XY) is used, for cross-references to further documents, listed under literature, the symbol (→  [Z]).



1 Safety

1.1 Symbols Used

Symbols for residual risks

DANGER

Information on preventing any kind of physical injury.

WARNING

Information on preventing extensive equipment and environmental damage.

Caution

Information on correct handling or use. Disregard can lead to malfunctions or minor equipment damage.



1.2 Personnel Qualifications

Skilled personnel

All work described in this document may only be carried out by persons who have suitable technical training and the necessary experience or who have been instructed by the end-user of the product.

1.3 General Safety Instructions

- Adhere to the applicable regulations and take the necessary precautions for the process media used.
Consider possible reactions between the materials (→ 5) and the process media.
Consider possible reactions (e.g. explosion) of the process media due to the heat generated by the product.
- Adhere to the applicable regulations and take the necessary precautions for all work you are going to do and consider the safety instructions in this document.
- Before beginning to work, find out whether any vacuum components are contaminated. Adhere to the relevant regulations and take the necessary precautions when handling contaminated parts.

Communicate the safety instructions to other users.

1.4 Liability and Warranty

Pfeiffer Vacuum assumes no liability and the warranty becomes null and void if the end-user or third parties

- disregard the information in this document
- use the product in a non-conforming manner
- make any kind of changes (modifications, alterations etc.) to the product
- use the product with accessories not listed in the corresponding product documentation.

The end-user assumes the responsibility in conjunction with the process media used.

Gauge failures due to contamination or wear and tear as well as expendable parts (e.g. filaments) are not covered by the warranty.



2 Technical Data

Measurement	Display range (air, O ₂ , CO, N ₂)	5×10 ⁻¹⁰ ... 1000 mbar, continuous
	Measuring range (air, O ₂ , CO, N ₂)	1×10 ⁻⁸ ... 10 ⁻² mbar, continuous
	Accuracy	15% of reading (after 5 min stabilization)
	Repeatability	5% of reading (after 5 min stabilization)
	Gas type dependence	→ Appendix B

Emission	Switching on threshold	2.4×10 ⁻² mbar
	Switching off threshold	3.2×10 ⁻² mbar
	Emission current	
	p ≤ 7.2×10 ⁻⁶ mbar	5 mA
	7.2×10 ⁻⁶ mbar < p < 3.2×10 ⁻² mbar	25 µA
	Emission current switching	
25 µA ⇒ 5 mA	7.2×10 ⁻⁶ mbar	
5 mA ⇒ 25 µA	3.2×10 ⁻⁵ mbar	

Degas	Degas emission current (p < 7.2×10 ⁻⁶ mbar)	≈ 16 mA (P _{degas} ≈ 4 W)
	Control input signal	0 V/+24 VDC, active high (control via RS232 → 17)
	Duration	max. 3 min, followed by automatic stop

In degas mode, ITR 90 gauges keep supplying measurement values, however their tolerances may be higher than during normal operation.

Output signal	Output signal (measuring signal)	0 ... +10 V
	Display range	0.774 V ... +10 V (5×10 ⁻¹⁰ mbar ... 1000 mbar)
	Relationship voltage-pressure	logarithmic, 0.75 V/decade (→ Appendix A)
	Error signal	< 0.3 V/0.5 V (→ 23)
	Minimum load impedance	10 kΩ

Power supply

DANGER

The gauge must only be connected to power supplies, instruments or control devices that conform to the requirements of a grounded extra-low voltage (PELV). The connection to the gauge has to be fused (Pfeiffer Vacuum controller fulfill these requirements).

Operating voltage at the ITR 90	+24 VDC (20 ... 28 VDC) ¹⁾ ripple max. 2 V _{pp}
Power consumption	
Standard	≤ 0.5 A
Degas	≤ 0.8 A
Emission start (<200 ms)	≤ 1.4 A
Power consumption	≤ 16 W
Fuse necessary	1.25 AT

¹⁾ Measured at sensor cable connector (consider the voltage drop as a function of the sensor cable length).



Sensor cable	Electrical connector	D-Sub, 15-pin, male (→ 13)
	Cable for ITR 90	
	Analog values only Without degas function	4 conductors plus shielding
	Analog values With degas function	5 conductors plus shielding
	Analog values With degas function And RS232C interface	7 conductors plus shielding
	Max. cable length (supply voltage 24 V ¹⁾)	
	Analog operation	≤35 m, conductor cross-section 0.25 mm ² ≤50 m, conductor cross-section 0.34 mm ² ≤100 m, conductor cross-section 1.0 mm ²
	RS232C operation	≤30 m
	Gauge identification	42 kΩ resistor between Pin 10 (sensor cable) and GND
	RS232C interface	Data rate
Data format		binary 8 data bits one stop bit no parity bit no handshake
Connections (sensor cable connector)		
TxD (Transmit Data)		Pin 13
RxD (Receive Data)		Pin 14
GND		Pin 5
<u>Function and interface protocol of the RS232C interface → 17</u>		
Vacuum	Materials exposed to vacuum	
	Housing, supports, screens	stainless steel
	Feedthroughs	NiFe, nickel plated
	Insulator	glass
	Cathode	iridium, yttrium oxide (Y ₂ O ₃)
	Cathode holder	molybdenum
	Pirani element	tungsten, copper
Internal volume		
DN 25 ISO-KF	≤24 cm ³	
DN 40 CF-R	≤34 cm ³	
Max. Pressure	2 bar (absolute)	
Weight	DN 25 ISO-KF	≈290 g
	DN 40 CF-R	≈550 g
Ambiance	Admissible temperatures	
	Storage	-20 ... 70 °C
	Operation	0 ... 50 °C
	Bakeout	+150 °C (without electronics unit)
	Relative humidity (year's mean / during 60 days)	≤65 / 85% (no condensation)
	Use	indoors only altitude up to 2000 m NN
	Type of protection	IP 30



Dimensions [mm]

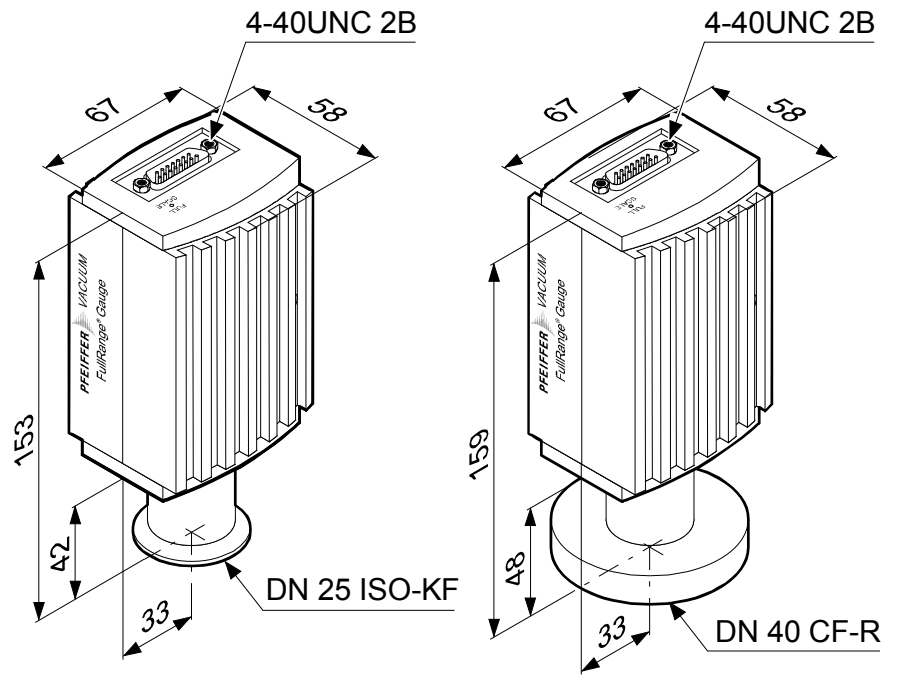

3 Installation

3.1 Vacuum Connection



DANGER

DANGER: overpressure in the vacuum system >1 bar
Injury caused by released parts and harm caused by escaping process gases can result if clamps are opened while the vacuum system is pressurized.
Do not open any clamps while the vacuum system is pressurized. Use the type of clamps which are suited to overpressure.



DANGER

The gauge must be electrically connected to the grounded vacuum chamber. This connection must conform to the requirements of a protective connection according to EN 61010:

- CF connections fulfill this requirement
- For gauges with a KF vacuum connection, use a conductive metallic clamping ring.

Caution



Caution: vacuum component
Dirt and damages impair the function of the vacuum component.
When handling vacuum components, take appropriate measures to ensure cleanliness and prevent damages.



The gauge may be mounted in any orientation. To keep condensates and particles from getting into the measuring chamber, preferably choose a horizontal to upright position. See dimensional drawing for space requirements (→ [7](#)).

When installing the gauge, make sure that the area around the connector is accessible for the tools required for adjustment while the gauge is mounted (→ [21](#)).

When installing the gauge, allow for installing/deinstalling the connectors and accommodation of cable loops.

- The gauge is supplied with a built-in grid. For potentially contaminating applications and to protect the electrodes against light and fast charged particles, installation (→ [10](#)) of the optional baffle is recommended (→ [25](#)).
- The sensor can be baked at up to 150 °C. At temperatures exceeding 50 °C, the electronics unit has to be removed (→ [9](#)) or an extension (Option → [25](#)) has to be installed.



3.1.1 Making the Flange Connection

Procedure



It is recommended not to apply any vacuum grease.

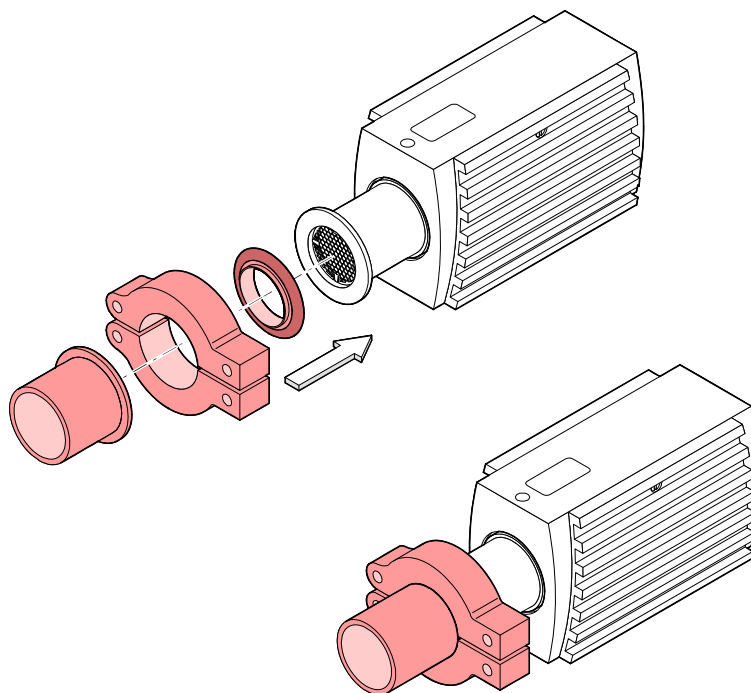

The protective lid will be needed for maintenance.

3.1.2 Removing and Installing the Electronics Unit

Required tool

- Allen key, size 2.5 mm

Removing the electronics unit



Unscrew the hexagon socket set screw (1) on the side of the electronics unit (2).

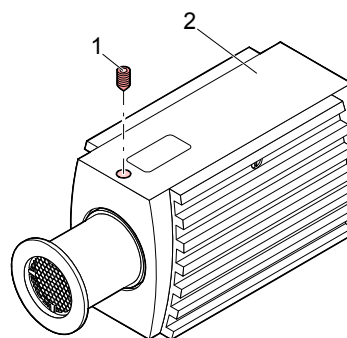

- 2 Remove the electronics unit without twisting it.

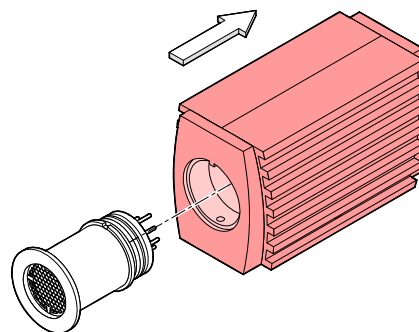

- ✓ Removal of the electronics unit is completed.

Installing the electronics unit

- 1 Place the electronics unit on the sensor (3) (be careful to correctly align the pins and notch (4)).

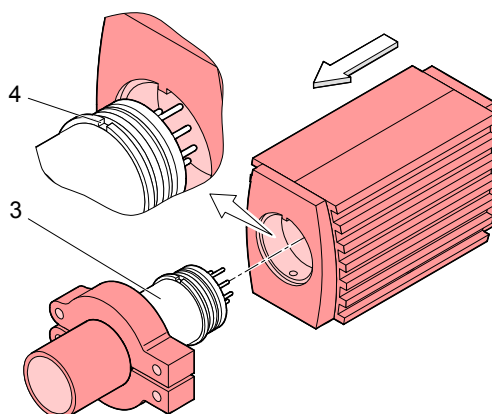

- 2 Slide the electronics unit in to the mechanical stop and lock it with the hexagon socket set screw (1).

- ✓ The electronics unit is now installed.

3.1.3 Using the Optional Baffle

In severely contaminating processes and to protect measurement electrodes optically against light and fast charged particles, replacement of the built-in grid by the optional baffle (→ 25) is recommended.

Installing/deinstalling the baffle

The optional baffle will be installed at the sensor opening of the deinstalled gauge (Deinstallation → 20).



Caution



Caution: dirt sensitive area

Touching the product or parts thereof with bare hands increases the desorption rate.

Always wear clean, lint-free gloves and use clean tools when working in this area.

Required tools / material

- Baffle (→ 25)
- Pointed tweezers
- Pin (e.g. pencil)
- Screwdriver No 1



Procedure

- 1 Carefully remove the grid with tweezers.

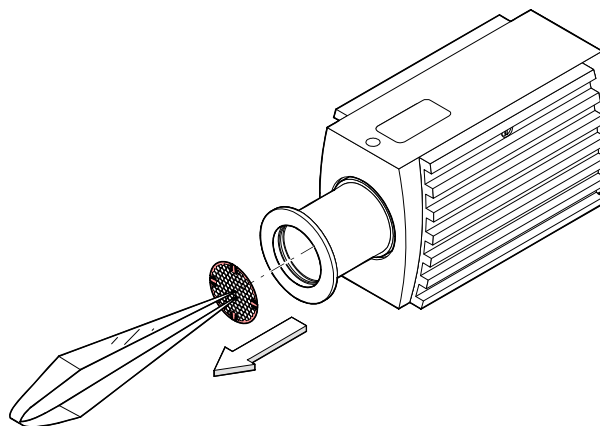

- 2 Carefully place the baffle onto the sensor opening.

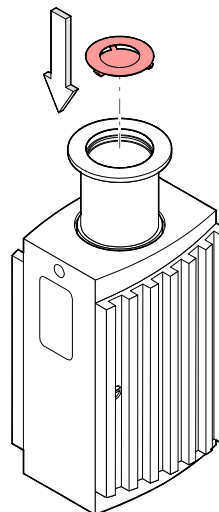

- 3 Using a pin, press the baffle down in the center until it catches.

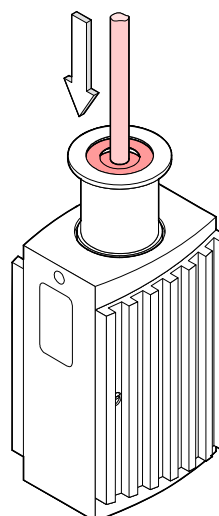

✓ The baffle is now installed (Installation of the gauge → 8).



Deinstallation

Carefully remove the baffle with the screwdriver.

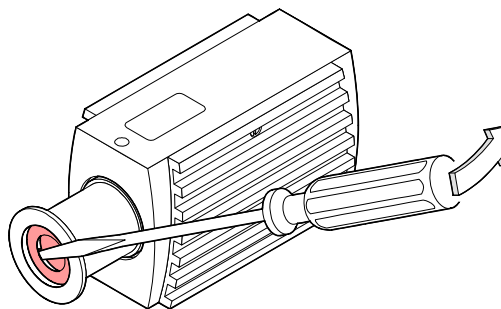

3.2 Electrical Connection

3.2.1 Use With Pfeiffer Vacuum Gauge Controllers

See Pfeiffer Vacuum sales literature and data sources for controllers and our range of sensor cables on our internet home page (www.pfeiffer-vacuum.com).

Procedure

- 1 Plug the sensor connector into the gauge and secure it with the locking screws.
- 2 Connect the other end of the sensor cable to the Pfeiffer Vacuum controller and secure it.

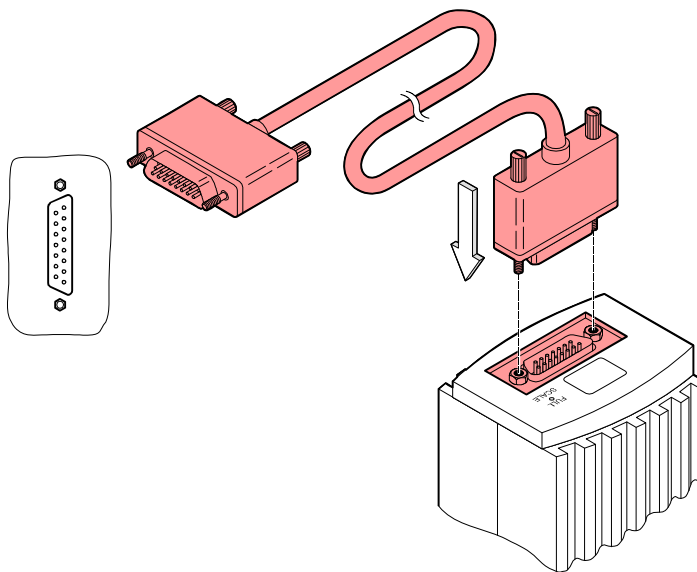

✓ The gauge can now be operated with the Pfeiffer Vacuum controller.

3.2.2 Use With Other Controllers

The gauge can also be operated with other controllers.

Cable type

The application and length of the sensor cable have to be considered when determining the number and cross sections of the conductors (→ 6).

Procedure

- 1 Open the cable connector (D-Sub, 15-pin, female).
- 2 Prepare the cable and solder/crimp it to the connector as indicated in the diagram of the gauge used:



Sensor cable connection
ITR 90

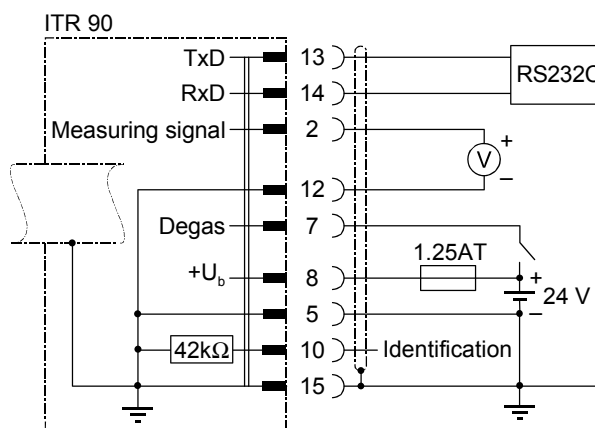

Electrical connection

- Pin 2 Signal output (measuring signal) 0 ... +10 V
 - Pin 5 Supply common, GND
 - Pin 7 Degas on, active high +24 VDC
 - Pin 8 Supply +24 VDC
 - Pin 10 Gauge identification
 - Pin 12 Signal common, GND
 - Pin 13 RS232C, TxD
 - Pin 14 RS232C, RxD
 - Pin 15 Shielding, housing, GND
- Pins 1, 3, 4, 6, 9 and 11 are not connected internally.

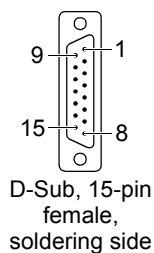

WARNING



The supply common (Pin 5) and the shielding (Pin 15) must be connected at the supply unit with protective ground. Incorrect connection, incorrect polarity or inadmissible supply voltages can damage the gauge.



For cable lengths up to 5 m (0.34 mm² conductor cross-section) the output signal can be measured directly between the positive signal output (Pin 2) and supply common GND (Pin 5) without loss of accuracy. At greater cable lengths, differential measurement between signal output (Pin 2) and signal common (Pin 12) is recommended.

3

Reassemble the cable connector.

4

On the other cable end, terminate the cable according to the requirements of the gauge controller you are using.



- 5** Plug the sensor connector into the gauge and secure it with the locking screws.

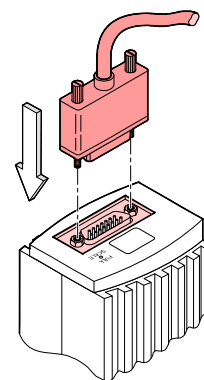

- 6** Connect the other end of the sensor cable to the connector of the instrument or gauge controller you are using.

✓ The gauge can now be operated via analog and RS232C interface.



4 Operation

4.1 Measuring Principle, Measuring Behavior

Bayard-Alpert

The ITR 90 vacuum gauge consist of two separate measuring systems (hot cathode Bayard-Alpert (BA) and Pirani).

The BA measuring system uses an electrode system according to Bayard-Alpert which is designed for a low x-ray limit.

The measuring principle of this measuring system is based on gas ionization. Electrons emitted by the hot cathode (F) ionize a number of molecules proportional to the pressure in the measuring chamber. The ion collector (IC) collects the thus generated ion current I^+ and feeds it to the electrometer amplifier of the measurement instrument. The ion current is dependent upon the emission current I_e , the gas type, and the gas pressure p according to the following relationship:

$$I^+ = I_e \times p \times C$$

Factor C represents the sensitivity of the gauge head. It is generally specified for N_2 .

The lower measurement limit is 5×10^{-10} mbar (gauge metal sealed).

To usefully cover the whole range of 5×10^{-10} mbar ... 10^{-2} mbar, a low emission current is used in the high pressure range (fine vacuum) and a high emission current is used in the low pressure range (high vacuum). The switching of the emission current takes place at decreasing pressure at approx. 7.2×10^{-6} mbar, at increasing pressure at approx. 3.2×10^{-5} mbar. At the switching threshold, the ITR 90 can temporarily (<2 s) deviate from the specified accuracy.

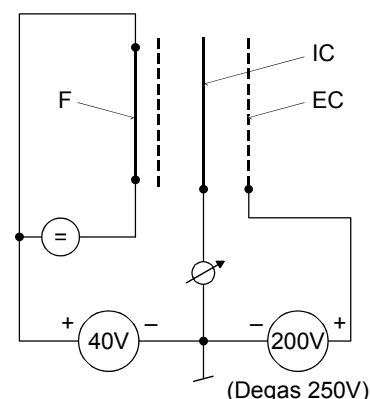
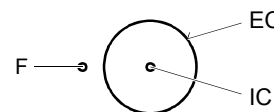

Diagram of the BA measuring system

- F hot cathode (filament)
- IC ion collector
- EC anode (electron collector)



Pirani

Within certain limits, the thermal conductivity of gases is pressure dependent. This physical phenomenon is used for pressure measurement in the thermal conductance vacuum meter according to Pirani. A self-adjusting bridge is used as measuring circuit (→ schematic). A thin tungsten wire forms the sensor element. Wire resistance and thus temperature are kept constant through a suitable control circuit. The electric power supplied to the wire is a measure for the thermal conductance and thus the gas pressure. The basic principle of the self-adjusting bridge circuit is shown in the following schematic.



Schematic

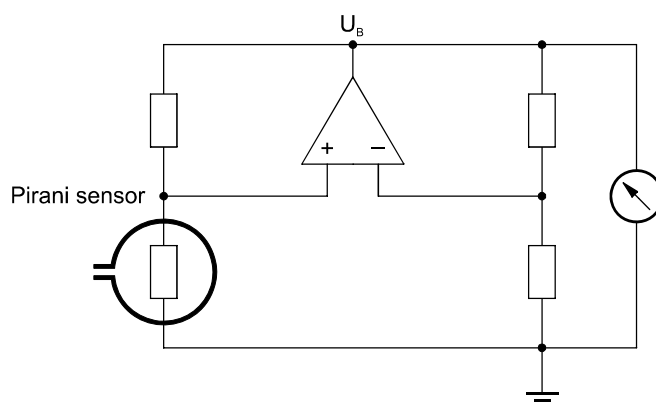

The bridge voltage U_b is a measure for the gas pressure and is further processed electronically (linearization, conversion).

Measuring range

The ITR 90 gauge continuously covers the measuring range 5×10^{-10} mbar ... 1000 mbar.

- The Pirani constantly monitors the pressure.
- The hot cathode (controlled by the Pirani) is activated only at pressures $< 2.4 \times 10^{-2}$ mbar.

If the measured pressure is higher than the switching threshold, the hot cathode is switched off and the Pirani measurement value is output.

If the Pirani measurement drops below the switching threshold ($p = 2.4 \times 10^{-2}$ mbar), the hot cathode is switched on. After heating up, the measured value of the hot cathode is fed to the output. In the overlapping range of 5.5×10^{-3} ... 2.0×10^{-2} mbar, the output signal is generated from both measurements.

Pressure rising over the switching threshold ($p = 3.2 \times 10^{-2}$ mbar) causes the hot cathode to be switched off. The Pirani measurement value is output.

Gas type dependence

The output signal is gas type dependent. The characteristic curves are accurate for dry air, N_2 and O_2 . They can be mathematically converted for other gases (\rightarrow Appendix B).

4.2 Operational Principle of the Gauge

The measuring currents of the Bayard-Alpert and Pirani sensor are converted into a frequency. A micro-controller converts this frequency into a digital value representing the measured total pressure. After further processing this value is available as analog measurement signal (0 ... +10 V) at the output (sensor cable connector Pin 2 and Pin 12). The maximum output signal is internally limited to +10 V (\approx atmosphere). The measured value can be read as digital value through the RS232C interface (Pins 13, 14, 15) (\rightarrow 17). The default setting of the displayed pressure unit is mbar. It can be modified via the RS232C interface (\rightarrow 17).

In addition to converting the output signal, the micro controller's functions include monitoring of the emission, calculation of the total pressure based on the measurements of the two sensors, and communication via RS232C interface.

4.3 Putting the Gauge Into Operation

When the operating voltage is supplied (\rightarrow Technical Data), the output signal is available between Pin 2 (+) and Pin 12 (-) of the sensor cable connector (Relationship output signal – pressure \rightarrow Appendix A).

Allow for a stabilizing time of approx. 10 min. Once the gauge has been switched on, permanently leave it on irrespective of the pressure.

Communication via the digital interface is described in a separate section.



4.4 Degas

Contamination



Gauge failures due to contamination or wear and tear as well as expendable parts (e.g. filaments) are not covered by the warranty.

Deposits on the electrode system of the BA gauge can lead to unstable measurement readings.

The degas process allows in-situ cleaning of the electrode system by heating the electron collector grid to approx. 700 °C by electron bombardment.

Depending on the application, this function can be activated by the system control via a digital interface. The ITR 90 automatically terminates the degas process after 3 minutes, if it has not been stopped before.



The degas process should be run at pressures below 7.2×10^{-6} mbar (emission current 5 mA).

For a repeated degas process, the control signal first has to change from ON (+24 V) to OFF (0 V), to then start degas again with a new ON (+24 V) command. It is recommended that the degas signal be set to OFF again by the system control after 3 minutes of degassing, to achieve an unambiguous operating status.

4.5 RS232C Interface

The built-in RS232C interface allows transmission of digital measurement data and instrument conditions as well as the setting of instrument parameters.

4.5.1 Description of the Functions

The interface works in duplex mode. A nine byte string is sent continuously without a request approx. every 20 ms.

Commands are transmitted to the gauge in a five byte input (receive) string.

Operational parameters

- Data rate 9600 Baud set value, no handshake
- Byte 8 data bits
 1 stop bit

Electrical connections

- TxD Pin 13
- RxD Pin 14
- GND Pin 5
(Sensor cable connector)

4.5.1.1 Output String (Transmit)

The complete output string (frame) is nine bytes (byte 0 ... 8). The data string is seven bytes (byte 1 ... 7).

Format of the output string

Byte No	Function	Value	Comment
0	Length of data string	7	(Set value)
1	Page number	5	(For ITR 90)
2	Status		→ Status byte
3	Error		→ Error byte
4	Measurement high byte	0 ... 255	→ Calculation of pressure value
5	Measurement low byte	0 ... 255	→ Calculation of pressure value
6	Software version	0 ... 255	→ Software version
7	Sensor type	10	(For ITR 90)
8	Check sum	0 ... 255	→ Synchronization



Synchronization

Synchronization of the master is achieved by testing three bytes:

Byte No	Function	Value	Comment
0	Length of data string	7	Set value
1	Page number	5	(For ITR 90)
8	Check sum of bytes No 1 ... 7	0 ... 255	Low byte of check sum ¹⁾

¹⁾ High order bytes are ignored in the check sum.

Status byte

Bit 1	Bit 0	Definition
0	0	Emission off
0	1	Emission 25 µA
1	0	Emission 5 mA
1	1	Degas
Bit 2	Definition	
0	1000 mbar adjustment off	
1	1000 mbar adjustment on	
Bit 3	Definition	
0 ↔ 1	Toggle bit, changes with every string received correctly	
Bit 5	Bit 4	Definition
0	0	Current pressure unit mbar
0	1	Current pressure unit Torr
1	0	Current pressure unit Pa
Bit 7	Bit 6	Definition
x	x	Not used

Error byte

Bit 3	Bit 2	Bit 1	Bit 0	Definition
x	x	x	x	Not used
Bit 7	Bit 6	Bit 5	Bit 4	Definition
0	1	0	1	Pirani adjusted poorly
1	0	0	0	BA error
1	0	0	1	Pirani error

Software version

The software version of the gauge can be calculated from the value of byte 6 of the transmitted string according to the following rule:

$$\text{Version No} = \text{Value}_{\text{Byte 6}} / 20$$

(Example: According to the above formula, Value_{Byte 6} of 32 means software version 1.6)

Calculation of the pressure value

The pressure can be calculated from bytes 4 and 5 of the transmitted string. Depending on the currently selected pressure unit (→ byte 2, bits 4 and 5), the appropriate rule must be applied.

As result, the pressure value results in the usual decimal format.

$$p_{\text{mbar}} = 10^{((\text{high byte} \times 256 + \text{low byte}) / 4000 - 12.5)}$$

$$p_{\text{Torr}} = 10^{((\text{high byte} \times 256 + \text{low byte}) / 4000 - 12.625)}$$

$$p_{\text{Pa}} = 10^{((\text{high byte} \times 256 + \text{low byte}) / 4000 - 10.5)}$$



Example

The example is based on the following output string:

Byte No	0	1	2	3	4	5	6	7	8
Value	7	5	0	0	242	48	20	10	69

The instrument or controller (receiver) interprets this string as follows:

Byte No	Function	Value	Comment
0	Length of data string	7	(Set value)
1	Page number	5	ITR 90
2	Status	0	Emission = off Pressure unit = mbar
3	Error	0	No error
4	Measurement High byte	242	Calculation of the pressure: $p = 10^{((242 \times 256 + 48) / 4000 - 12.5)} = 1000 \text{ mbar}$
5	Low byte	48	
6	Software version	20	Software version = 20 / 20 = 1.0
7	Sensor type	10	ITR 90
8	Check sum	69	$5 + 0 + 0 + 242 + 48 + 20 + 10 = 325_{\text{dec}} \hat{=} 0145_{\text{hex}}$ High order byte is ignored \Rightarrow Check sum = $45_{\text{hex}} \hat{=} 69_{\text{dec}}$

4.5.1.2 Input String (Receive)

For transmission of the commands to the gauge, a string (frame) of five bytes is sent (without <CR>). Byte 1 to byte 3 form the data string.

Format of the input string

Byte no	Function	Value	Comment
0	Length of data string	3	(Set value)
1	Data		\rightarrow admissible input strings
2	Data		\rightarrow admissible input strings
3	Data		\rightarrow admissible input strings
4	Check sum (from bytes No 1 ... 3)	0 ... 255	(low byte of sum) ¹⁾

¹⁾ High order bytes are ignored in the check sum.

Admissible input strings

For commands to the gauge, six defined strings are used:

Command	Byte No				
	0	1	2	3	4 ²⁾
Set the unit mbar in the display	3	16	62	0	78
Set the unit Torr in the display	3	16	62	1	79
Set the unit Pa in the display	3	16	62	2	80
Power-failure-safe storage of current unit	3	32	62	62	156
Switch degas on (switches itself off after 3 minutes)	3	16	93	148	1
Switch degas off before 3 minutes	3	16	93	105	214

²⁾ Only low order byte of sum (high order byte is ignored).



5 Deinstallation

DANGER



DANGER: contaminated parts

Contaminated parts can be detrimental to health and environment.

Before beginning to work, find out whether any parts are contaminated. Adhere to the relevant regulations and take the necessary precautions when handling contaminated parts.



Caution



Caution: vacuum component

Dirt and damages impair the function of the vacuum component.

When handling vacuum components, take appropriate measures to ensure cleanliness and prevent damages.

Procedure

- 1 Vent the vacuum system.



Before taking the gauge out of operation, make sure that this has no adverse effect on the vacuum system.

Depending on the programming of the superset controller, faults may occur or error messages may be triggered.

Follow the appropriate shut-down and starting procedures.

- 2 Take gauge out of operation.
- 3 Disconnect all cables from the gauge.
- 4 Remove gauge from the vacuum system and replace the protective lid.

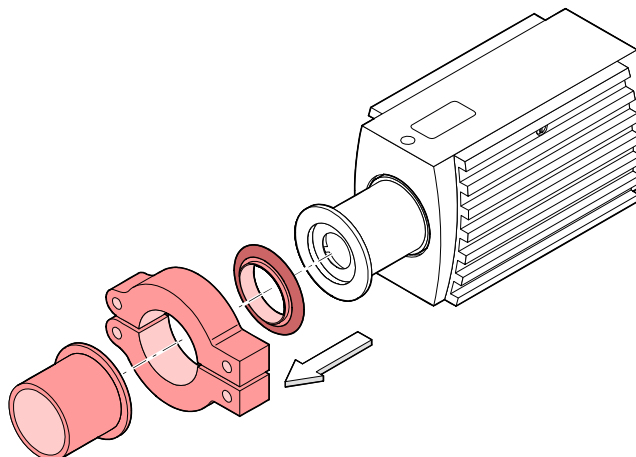

6 Maintenance, Repair

6.1 Maintenance



STOP DANGER

DANGER: contaminated parts

Contaminated parts can be detrimental to health and environment. Before beginning to work, find out whether any parts are contaminated. Adhere to the relevant regulations and take the necessary precautions when handling contaminated parts.

The product is maintenance-free, if clean operating conditions are met.

6.1.1 Cleaning the Gauge

Small deposits on the electrode system can be removed by baking the anode (Degas → 17). In the case of severe contamination, the baffle can be exchanged easily (→ 10). The sensor itself cannot be cleaned and needs to be replaced in case of severe contamination (→ 24).

A slightly damp cloth normally suffices for cleaning the outside of the unit. Do not use any aggressive or scouring cleaning agents.



Make sure that no liquid can penetrate the product. Allow the product to dry thoroughly before putting it into operation again.



Gauge failures due to contamination or wear and tear as well as expendable parts (e.g. filaments) are not covered by the warranty.

6.2 Adjusting the Gauge

The gauge is factory-calibrated. Through the use in different climatic conditions, fitting positions, aging or contamination (→ 17) and after exchanging the sensor (→ 24) a shifting of the characteristic curve can occur and readjustment can become necessary. Only the Pirani part can be adjusted.

6.2.1 Adjustment at Atmospheric Pressure

At the push of a button the digital value and thus the analog output are adjusted electronically to 10 V at atmospheric pressure.

Adjustment is necessary if

- at atmospheric pressure, the output signal is < 10 V
- at atmosphere, the digital value of the RS232C interface is < atmospheric pressure
- when the vacuum system is vented, the output voltage reaches 10 V (limited to 10 V by the software) before the measured pressure has reached atmosphere
- when the vacuum system is vented, the digital value of the RS232C interface reaches its maximum before the measured pressure has reached atmosphere.

Required tools

- Pin approx. $\varnothing 1.3 \times 50$ mm (e.g. a bent open paper clip)

Procedure



Operate gauge for approx. 10 minutes at atmospheric pressure.



If the gauge was operated before in the BA range, a cooling-down time of approx. 30 minutes is to be expected (gauge temperature = ambient temperature).



- 2 Insert the pin through the opening marked <FULL SCALE> and push the button inside for at least 5 s.

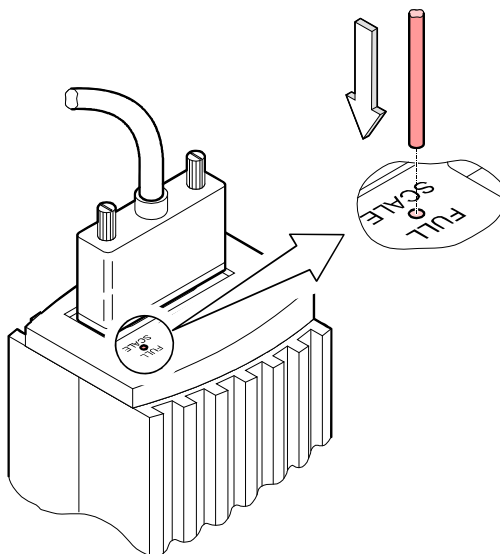

The gauge is automatically adjusted (≈ 10 s).



The gauge is now adjusted at atmospheric pressure.

6.2.2 Zero Point Adjustment

A zero point adjustment is recommended

- after the sensor has been exchanged
- as part of the usual maintenance work for quality assurance

Required tools

- Pin approx. $\varnothing 1.3 \times 50$ mm (e.g. a bent open paper clip)

Procedure

The push button <FULL SCALE> is also used for the zero point adjustment (\rightarrow Illustration in "Adjustment at Atmospheric Pressure").



Operate gauge for approx. 10 minutes at a pressure of 1×10^{-4} mbar.



Insert the pin through the opening marked <FULL SCALE> and push the button inside for 2 s.



The adjustment is done automatically and ends after 2 minutes.



The zero point of the gauge is now adjusted.



6.3 What to Do in Case of Problems

Required tools / material

- Voltmeter / ohmmeter
- Allen key, size 2.5 mm
- Spare sensor (if the sensor is faulty)

Troubleshooting

The output signal is available at the sensor cable connector (Pin 2 and Pin 12).



In case of an error, it may be helpful to just turn off the mains supply and turn it on again after 5 s.

Problem	Possible cause	Correction
Output signal permanently $\approx 0V$	Sensor cable defective or not correctly connected	Check the sensor cable
	No supply voltage	Turn on the power supply
	Gauge in an undefined status	Turn the gauge off and on again (reset)
Output signal $\approx 0.3 V$	Hot cathode error (sensor faulty)	Replace the sensor (\rightarrow 24)
Output signal $\approx 0.5 V$	Pirani error (sensor defective)	Replace the sensor (\rightarrow 24)
	Electronics unit not mounted correctly on sensor	Check the connection the electronics unit - sensor
No signal	Internal data connection not working	Turn the gauge off and on again after 5 s Replace the electronics unit
Gauge does not switch over to BA at low pressures	Pirani zero point out of tolerance	Carry out a zero point adjustment (\rightarrow 22)

Troubleshooting (sensor)

If the cause of a fault is suspected to be in the sensor, the following checks can be made with an ohmmeter (the vacuum system need not be vented for this purpose). Separate the sensor from the electronics unit (\rightarrow 9). Using an ohmmeter, make the following measurements.

Ohmmeter measurement between pins	\approx	\gg or \ll	Possible cause
2 + 4	$\approx 37 \Omega$	$\gg 37 \Omega$	Pirani element 1 broken
4 + 5	$\approx 37 \Omega$	$\gg 37 \Omega$	Pirani element 2 broken
6 + 7	$\approx 0.15 \Omega$	$\gg 0.15 \Omega$	Filament of hot cathode broken
4 + 1	∞	$\ll \infty$	Electrode - short circuit to ground
6 + 1	∞	$\ll \infty$	Electrode - short circuit to ground
3 + 1	∞	$\ll \infty$	Electrode - short circuit to ground
9 + 1	∞	$\ll \infty$	Electrode - short circuit to ground
6 + 3	∞	$\ll \infty$	Short circuit between electrodes
9 + 3	∞	$\ll \infty$	Short circuit between electrodes



View on sensor pins

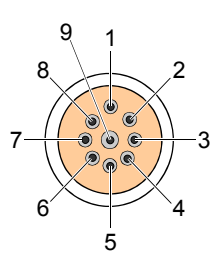

- 6 ● Hot cathode ca. 0.15 Ohm
- 7 ● Not connected
- 8 ● Not connected
- 2 ● Pirani sensor 1 ca. 37 Ohm
- 4 ● Pirani sensor 2 ca. 37 Ohm
- 5 ● Anode
- 3 ● GND (connected to sensor housing)
- 1 ● Ion collector

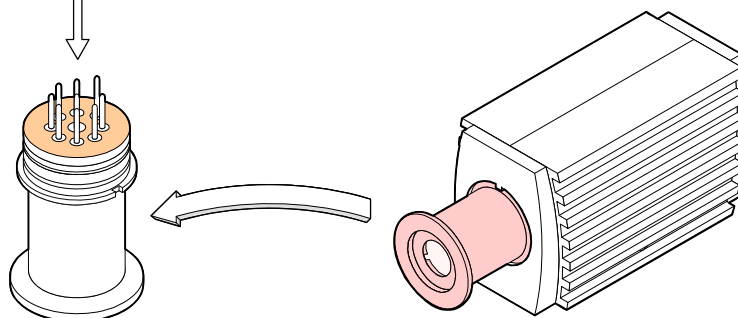

Correction

All of the above faults can only be remedied by replacing the sensor (→ 24).

6.4 Replacing the Sensor

Replacement is necessary, when

- the sensor is severely contaminated
- the sensor is mechanically deformed
- the sensor is faulty, e.g. filament of hot cathode broken (→ 23)
- the sensor is faulty, e.g. Pirani element broken (→ 23)



Gauge failures due to contamination or wear and tear as well as expendable parts (e.g. filaments) are not covered by the warranty.

Required tools / material

- Allen key, size 2.5 mm
- Spare sensor (→ 25)

Procedure

- 1 Deinstall the gauge (→ 20).
 - 2 Deinstall the electronics unit from the faulty sensor and mount it to the new sensor (→ 9).
 - 3 Adjust the gauge (→ 21).
- ✓ The new sensor is now installed.



7 Options

	Ordering No.
Bake-out extension 100 mm	PT 590 300-T
Baffle DN 25 ISO-KF / DN 40 CF-R (→ 10)	PT 120 124-T

8 Spare Parts

When ordering spare parts, always indicate:

- All information on the product nameplate
- Description and part number

	Ordering No.
Replacement sensor ITR 90, flange DN 25 ISO-KF (including allen key)	PT 120 121-T
Replacement sensor ITR 90, flange DN 40 CF-R (including allen key)	PT 120 123-T

9 Storage



Caution



Caution: vacuum component

Inappropriate storage leads to an increase of the desorption rate and/or may result in mechanical damage of the product.

Cover the vacuum ports of the product with protective lids or grease free aluminum foil. Do not exceed the admissible storage temperature range (→ 6).



10 Returning the Product

WARNING

WARNING: forwarding contaminated products
 Contaminated products (e.g. radioactive, toxic, caustic or biological hazard) can be detrimental to health and environment.
 Products returned to Pfeiffer Vacuum should preferably be free of harmful substances. Adhere to the forwarding regulations of all involved countries and forwarding companies and enclose a duly completed declaration of contamination (form under "www.pfeiffer-vacuum.com").

Products that are not clearly declared as "free of harmful substances" are decontaminated at the expense of the customer.

Products not accompanied by a duly completed declaration of contamination are returned to the sender at his own expense.

11 Disposal

DANGER

DANGER: contaminated parts
 Contaminated parts can be detrimental to health and environment.
 Before beginning to work, find out whether any parts are contaminated. Adhere to the relevant regulations and take the necessary precautions when handling contaminated parts.

WARNING

WARNING: substances detrimental to the environment
 Products or parts thereof (mechanical and electric components, operating fluids etc.) can be detrimental to the environment.
 Dispose of such substances in accordance with the relevant local regulations.

Separating the components

After disassembling the product, separate its components according to the following criteria:

Contaminated components

Contaminated components (radioactive, toxic, caustic or biological hazard etc.) must be decontaminated in accordance with the relevant national regulations, separated according to their materials, and disposed of.

Other components

Such components must be separated according to their materials and recycled.



Appendix

A: Relationship Output Signal – Pressure

Conversion formulae

$$p = 10^{(U - 7.75) / 0.75 + c}$$

$$U = 0.75 \times (\log p - c) + 7.75$$

where

U	p	c
[V]	[mbar]	0
[V]	[Pa]	2
[V]	[Torr]	-0.125

Conversion curve

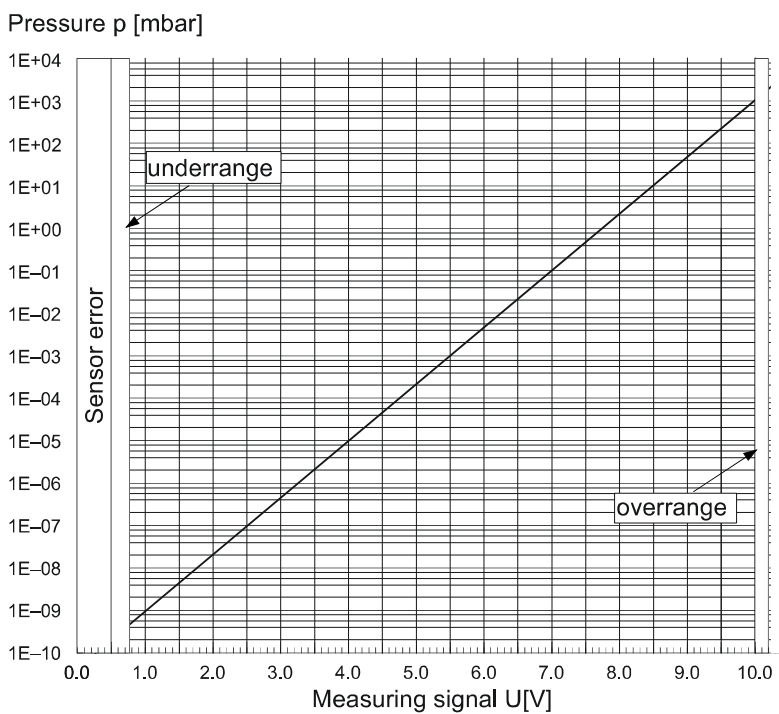

Conversion table

Output signal U [V]	[mbar]	Pressure p [Torr]	[Pa]
0.3 / 0.5		Sensor error (→ 23)	
0.51 ... 0.774		Inadmissible range	
0.774	5×10^{-10}	3.75×10^{-10}	5×10^{-8}
1.00	1×10^{-9}	7.5×10^{-10}	1×10^{-7}
1.75	1×10^{-8}	7.5×10^{-9}	1×10^{-6}
2.5	1×10^{-7}	7.5×10^{-8}	1×10^{-5}
3.25	1×10^{-6}	7.5×10^{-7}	1×10^{-4}
4.00	1×10^{-5}	7.5×10^{-6}	1×10^{-3}
4.75	1×10^{-4}	7.5×10^{-5}	1×10^{-2}
5.50	1×10^{-3}	7.5×10^{-4}	1×10^{-1}
6.25	1×10^{-2}	7.5×10^{-3}	1×10^0
7.00	1×10^{-1}	7.5×10^{-2}	1×10^1
7.75	1×10^0	7.5×10^{-1}	1×10^2
8.50	1×10^1	7.5×10^0	1×10^3
9.25	1×10^2	7.5×10^1	1×10^4
10.00	1×10^3	7.5×10^2	1×10^5
>10.00		Inadmissible range	

B: Gas Type Dependence

Indication range above 10^{-2} mbar

Pressure indicated (gauge adjusted for air, Pirani-only mode)

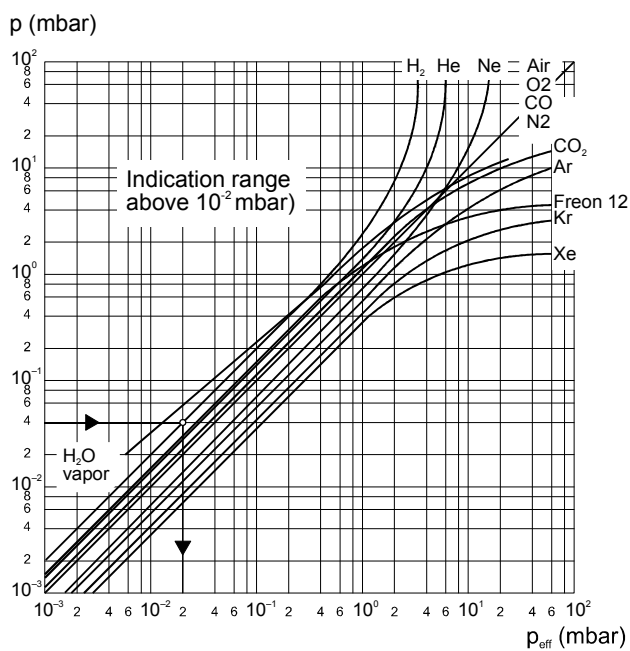

Calibration in pressure range
 $10^{-2} \dots 1$ mbar

The gas type dependence in the pressure range $10^{-2} \dots 1$ mbar can be compensated by means of the following formula:

$$p_{\text{eff}} = C \times \text{indicated pressure}$$

where	Gas type	Calibration factor C
	Air, O ₂ , CO	1.0
	N ₂	0.9
	CO ₂	0.5
	Water vapor	0.7
	Freon 12	1.0
	H ₂	0.5
	He	0.8
	Ne	1.4
	Ar	1.7
	Kr	2.4
	Xe	3.0

(The above calibration factors are mean values)

Calibration in pressure range
 $<10^{-3}$ mbar

The gas type dependence in the pressure range $<10^{-3}$ mbar can be compensated by means of the following formula (gauge adjusted for air):

$$p_{\text{eff}} = C \times \text{indicated pressure}$$

where	Gas type	Calibration factor C
	Air, O ₂ , CO, N ₂	1.0
	N ₂	1.0
	He	5.9
	Ne	4.1
	H ₂	2.4
	Ar	0.8
	Kr	0.5
	Xe	0.4

(The above calibration factors are mean values)



A mixture of gases and vapors is often involved. In this case, accurate determination is only possible with a partial-pressure measuring instrument.

C: Literature

[1] www.pfeiffer.vacuum.com
 Instruction Sheet
 FullRange® Bayard-Alpert Gauge ITR 90
 BG 5039 BDE German
 BG 5039 BEN English
 Pfeiffer Vacuum GmbH, D-35614 Asslar, Deutschland



Notes



Notes



**Vacuum solutions
from a single source**

Pfeiffer Vacuum stands for innovative and custom vacuum solutions worldwide, technological perfection, competent advice and reliable service.

**Complete range
of products**

From a single component to complex systems: We are the only supplier of vacuum technology that provides a complete product portfolio.

**Competence in
theory and practice**

Benefit from our know-how and our portfolio of training opportunities! We can support you with your plant layout and provide first-class on-site-service worldwide.

**Are you looking for a
perfect vacuum solution?
Please contact us:**

Pfeiffer Vacuum GmbH
Headquarters • Germany
Tel.: +49 (0) 6441 802-0
info@pfeiffer-vacuum.de
www.pfeiffer-vacuum.com

